

# Piano

LIFE SAVER SYSTEM<sup>®</sup>

from  
DAMPP-CHASER



## Instructions for Replacing Humidifier Pads

Model UHP- 4-Pack

With this package, you can make (2) pad changes for tall Vertical tanks or (4) pad changes for any other Damp-Chaser Humidifier.

Package Contains:

- (4) 30-inch pads,
- (1) clear liner for tall Vertical Tanks
- (1) black liners for Universal Tanks



Use the 30" pads  
FULL LENGTH  
for tall Vertical  
Humidifiers

3-3/4" wide  
x 13" long x 9" deep

Cut the pads in HALF to fit these tanks:

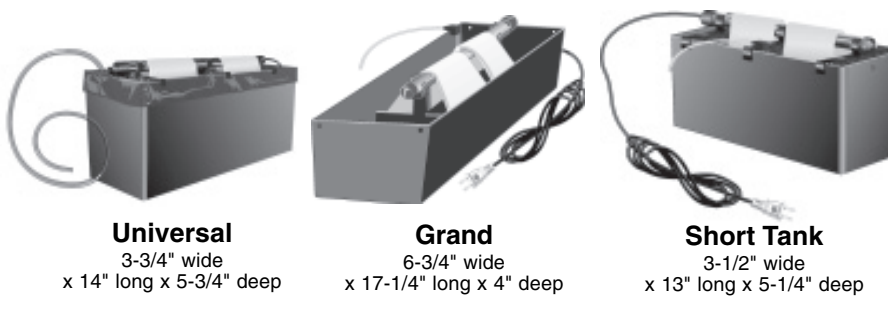

### A. Replacing Pads

1) *Drape the pads across the heater bar and push them down into the tank. To replace a liner, remove the tank from the piano (see #2 below).*

Humidifier Pads should be changed at least twice a year. To ensure a properly functioning Humidifier, change the pads during the fall and then, change them again in the spring.

In some cases, depending upon the location of the Humidifier, it is possible to change the pads without removing the Humidifier tank simply by removing the old ones from the heater bar and replacing them with the new pads. If the baffle above the grand tank is disturbed, make sure it is straightened out after putting the new pads in place.

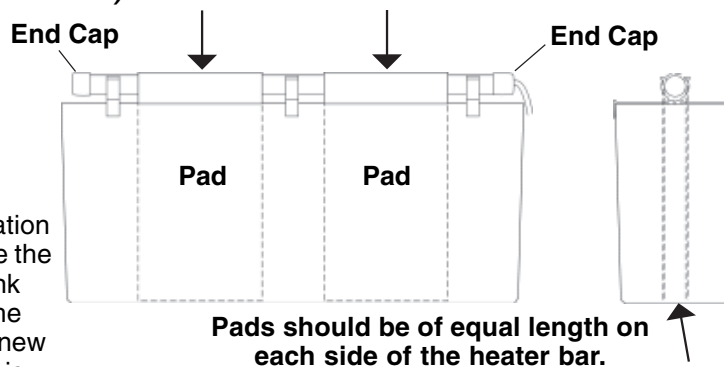

2) **If it is necessary to remove the tank to install a new liner and change pads, the water in the tank should be emptied.**

**Grand Piano:** Under the piano, place a receptacle below the tank. Loosen the wing nut that holds the watering tube and remove the tube from the tank. Remove the old pads from the Humidifier heater bar and place them in a container, (be careful not to drip water on the floor). Remove the heater bar and the Water Sensor probes. Unclip one end of the tank from the hanger rod by pushing the end of the tank upward. Slowly lower the freed end until water spills over into the receptacle. Remove the tank completely (by unclipping the end of the Humidifier that is still attached to a hanger rod) and empty the tank completely. If it is the Universal Humidifier (see dimensions above), remove the old liner and replace it with a new one. If you have an older Grand or Short tank Humidifier, you can clean it by using warm soapy water. Hang the Humidifier tank back on the hanger rods. Then, use the wing nut to remount the watering tube and replace the other Humidifier components. Drape the new pads across the Humidifier heater bar. (Be sure the end of the watering tube is inside the plastic liner for the Universal Humidifier.) Fill the tank through the watering tube according to directions on the watering can or the Care and Maintenance instructions.

**Vertical (Upright) Piano:** Remove the piano's bottom panel. Loosen the wing nut on the tank which holds the watering tube and remove the tube from the tank. Remove the old pads from the Humidifier heater bar and place them in a container, (be careful not to drip water on the floor). Remove the heater bar and the Water Sensor probes. Lift the tank out of the piano and empty the water into a receptacle. Remove the old liner and replace with a new one. Replace the Humidifier in the piano. Use the wing nut to remount the watering tube and then replace the other Humidifier components. Drape the new pads across the Humidifier heater bar. (Be sure the end of the watering tube is inside the plastic liner). Fill the tank through the watering tube according to directions on the watering can or the Care and Maintenance instructions.

#### **B. Add water to the Humidifier Tank**

If your tap water comes from a well or is "hard" water, meaning containing significant minerals, we recommend using distilled water. If distilled water is used, add a capful of Humidifier Treatment (see below) or 1/4 cup of tap water to insure there are adequate electrolytes in the Humidifier to support operation of the yellow Water Sensor Light. Without sufficient electrolytes, the light will blink continuously, even when the tank is full. **Do not put salt in the Humidifier, as it is corrosive.**

#### **C. If your System is equipped with a Smart Bracket (SB)**

When the red light marked **PADS** on the light panel blinks, the Smart Bracket (SB) bar has sensed that the pads are not wicking water across the bar. The SB sensor wires, that run the length of the heater bar, can sense the condition of the pads only if the wires are kept reasonably free from mineral build-up. During pad changing, remove the SB from the heater bar: then, remove mineral residue on the wires by carefully scraping the wires with the edge of a knife held perpendicular to the wire. Alternatively, it may be simpler to bring a new SB to replace the old one. Replacement SB's are available from your Dampp-Chaser distributor.

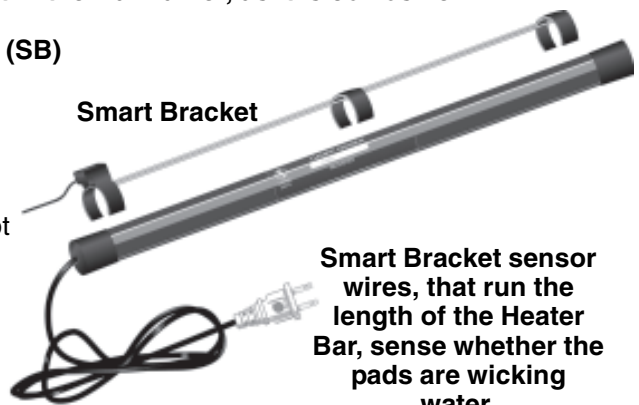

**Smart Bracket sensor wires, that run the length of the Heater Bar, sense whether the pads are wicking water.**

#### **D. Use Dampp-Chaser Humidifier Treatment regularly**

Humidifier Treatment inhibits bacterial and algae growth in the Humidifier tank and watering tube. The Treatment is available from your technician or call Dampp-Chaser at (800) 438-1524. Use according to directions on the bottle.

***WARNING: Add only the Dampp-Chaser brand of Humidifier Treatment to the Humidifier water. Other brands of humidifier treatment may contain acids which can corrode strings and metal parts in the piano. The use of other humidifier treatment preparations will void the warranty of the Piano Life Saver System and may void the warranty of the piano manufacturer.***



**Dampp-Chaser Corporation**  
(800) 438-1524 · Tel: (828) 692 8271 · Fax: (828) 692 8272  
P. O. Box 1610 · Hendersonville, NC 28793  
website: [www.PianoLifeSaver.com](http://www.PianoLifeSaver.com) · email: [piano@dampp-chaser.com](mailto:piano@dampp-chaser.com)